

QuickStart for Model 8500 Garage Door Opener

LiftMaster
ELITE SERIES®

This QuickStart is intended to highlight a typical situation. These instructions are not intended to be comprehensive. Because each application is unique, it is the responsibility of the purchaser, designer, installer and end user to ensure that the total door system is safe for intended use. Please consult the manual and/or a qualified technician for further information.

⚠ WARNING

To Reduce the Risk of SEVERE INJURY or DEATH, READ AND FOLLOW ALL INSTALLATION INSTRUCTIONS provided in the manual. This QuickStart is NOT intended to replace the manual, but serves as a reminder for those familiar with the manual and the installation of this product.

INSTALLATION

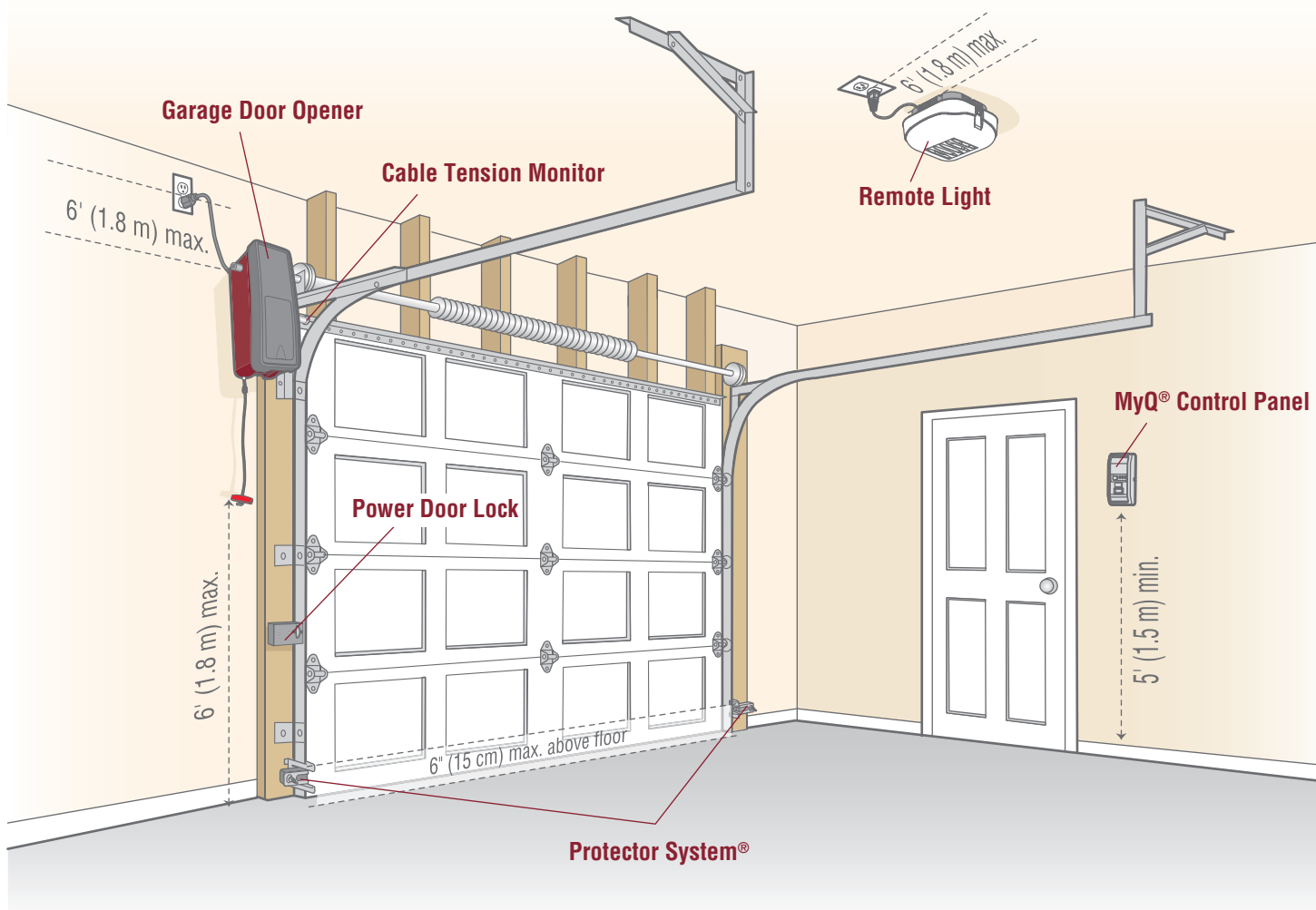

WIRE CONNECTIONS

- A** Power Door Lock
(white and white/black)
- B** Cable Tension Monitor
(white/green to green)
- C** MyQ® Control Panel
(white/red to red, white to white)
- D** Safety Reversing Sensors
(white/black to gray, white to white)

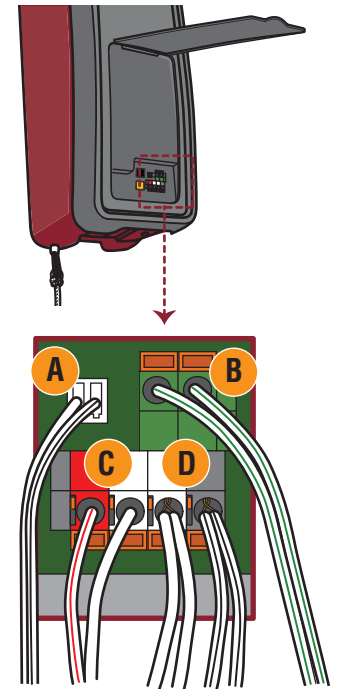

1 Install the operator.

STEP 1: Slide the collar onto the motor shaft on the garage door opener and hand tighten the collar screws.

3/16"

Motor Shaft

Collar

STEP 2: Loosely attach the mounting bracket to the garage door opener.

Mounting Bracket

STEP 3: Slide the garage door opener onto the torsion bar and make sure it is level. Tighten the collar screws evenly. Lift the garage door slightly to access the set screws on the back of the collar. Tighten set screws.

Collar Screws

Set Screws

3/16"

1/8"

STEP 4: Tighten the screws attaching the mounting bracket to the garage door opener. Secure the mounting bracket to the wall.

STEP 5: Attach the emergency release rope and handle.

2 Install the power door lock.

A

5 Install the remote light.

A19 incandescent
(100 watt maximum)

3 Install the cable tension monitor.

B

1/8"-1/4"
(3-6 mm)

2'-6"
(5-15 cm)

Approx. 3/4"
(19 mm)

6 Install The Protector System®.

Install the bracket onto the door track no higher than 6" (15 cm) above the floor. Secure the sensor to the bracket. Repeat on opposite door track. Align the sensors.

Sensor

Bracket

6" (15 cm) max. above floor

Run wires to garage door opener.

D

Plug in the garage door opener. Check to make sure the LEDs in both sensors are glowing steadily (indicating they are aligned and wired correctly).

4 Install the MyQ® control panel.

C

R **W**

1 Program the Travel Limits

Travel limits regulate the points at which the door will stop when moving up or down.

STEP 1: Press and hold the black button until the LED starts flashing slowly, then release.

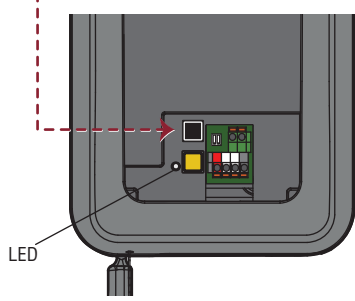

STEP 2: Push and hold the black button until the door reaches the desired UP (open) position.

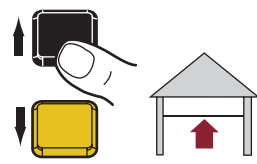

STEP 3: Push the door control or programmed remote control. This sets the UP (open) limit and begins closing the door.

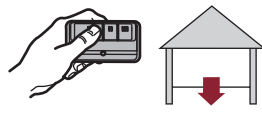

STEP 4: Immediately when the door begins to close, press and release either the black or yellow button. This will stop the door.

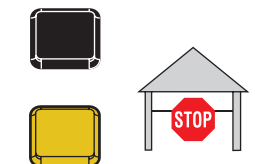

STEP 5: Push and hold the yellow button until the door reaches the desired DOWN (closed) position.

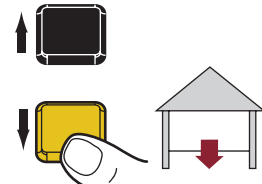

STEP 6: Once the door is closed, if there appears to be too much pressure on the door, you may toggle the door back and forth using the black and yellow buttons to reach the desired closed position.

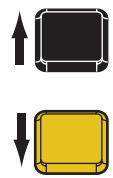

STEP 7: Push the door control or programmed remote control. This sets the DOWN (close) limit and the door should open.



2 Set the Force

The force setting measures the amount of force required to open and close the door.

STEP 1: Push the yellow button twice to enter into the Force Adjustment Mode. The LED will flash quickly.

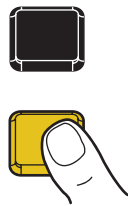

STEP 2: Push the door control or programmed remote control. The door will close (DOWN).



STEP 3: Push the door control or programmed remote control again. The door will open (UP).



STEP 4: Push the door control or programmed remote control a third time to close the door (DOWN).

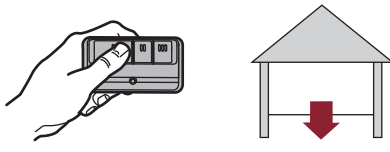

3 Test the Safety Reversal System

1. With the door fully open, place a 1-1/2 inch (3.8 cm) board (or a 2x4 laid flat) on the floor, centered under the garage door.
 2. Operate the door in the down direction. The door must reverse on striking the obstruction.
- If the door stops on the obstruction, it is not traveling far enough in the down direction. Complete Adjustment Steps 1 and 2 Program the Travel Limits and Set the Force. Repeat the test.

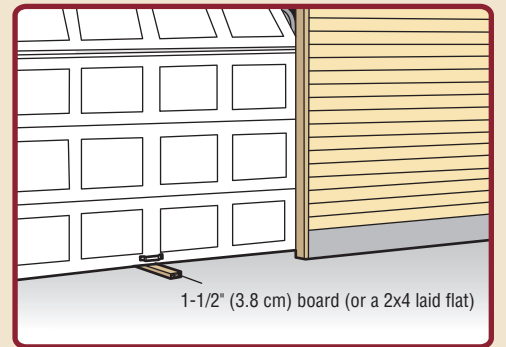

4 Test the Protector System®

1. Press the remote control push button to open the door.
2. Place the opener carton in the path of the door.
3. Press the remote control push button to close the door. The door will not move more than an inch, and the opener lights will flash.

The garage door opener will not close from a remote if the indicator light in either sensor is off (alerting you to the fact that the sensor is misaligned or obstructed).

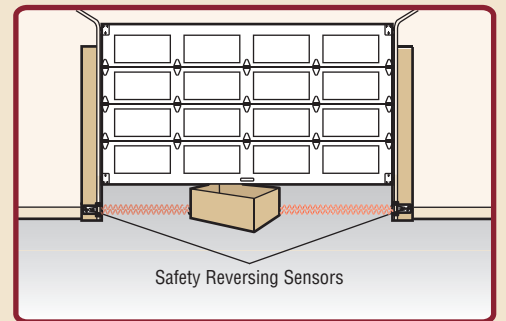

5 Test Cable Tension Monitor

With the door fully closed, push on the front of the cable tension monitor. A click should be heard. If there is no click, the roller may be hitting the jamb and not allowing the switch to detect slack in the cable. Make sure the cable tension monitor is mounted flush with the wall and the roller is free from any obstructions.

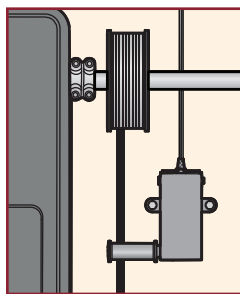

6 To Open the Door Manually

Disengage door lock before proceeding. The door should be fully closed if possible. Pull down on the emergency release handle until a click noise is heard from the garage door opener and lift the door manually.

To reconnect the door to the garage door opener, pull the emergency release handle straight down a second time until a click noise is heard from the garage door opener. The door will reconnect on the next UP or DOWN operation.

Test the emergency release:

1. Make sure the garage door is closed.
2. Pull the emergency release handle. The garage door should then be able to be opened manually.
3. Return the door to the closed position.
4. Pull the emergency handle a second time.
5. Reconnect the door to the garage door opener.

7 Test Power Door Lock

1. With the door fully closed, the power door lock bolt should be protruding through the track.
2. Operate the door in the open direction. The power door lock should retract before the door begins to move.
3. Operate the door in the down direction. When the door reaches the fully closed position, the power door lock should automatically activate to secure the door.

NOTE: If the power door lock does not function, the lock can be manually released by sliding the manual release handle to the open position.

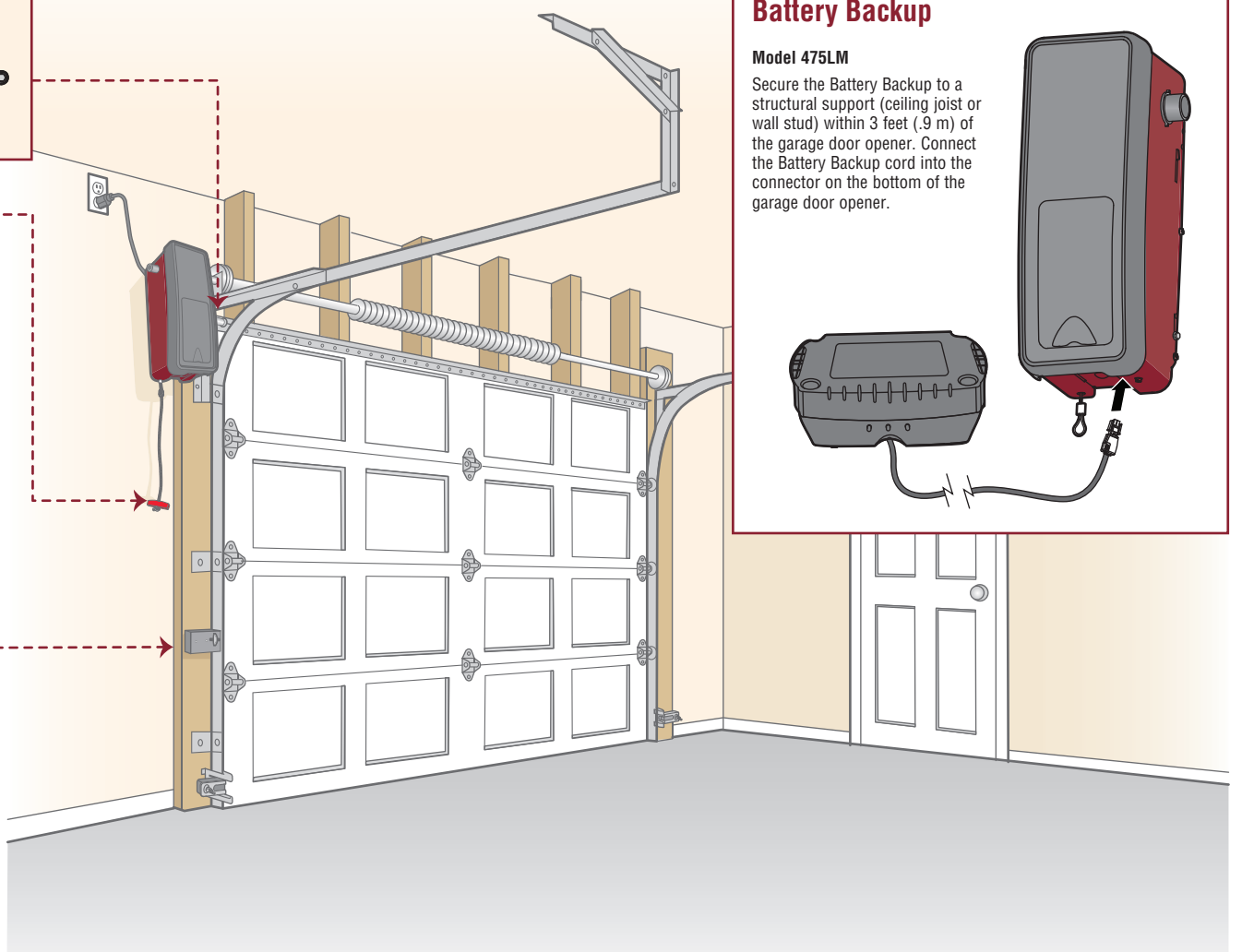

OPTIONAL

Battery Backup

Model 475LM

Secure the Battery Backup to a structural support (ceiling joist or wall stud) within 3 feet (.9 m) of the garage door opener. Connect the Battery Backup cord into the connector on the bottom of the garage door opener.

