

# ROLLING COUNTER DOOR

MODEL ESC20 (INTEGRAL FRAME)



## MEASURE THE WIDTH AND HEIGHT OF THE OPENING

### DOOR SIZE AND AREA

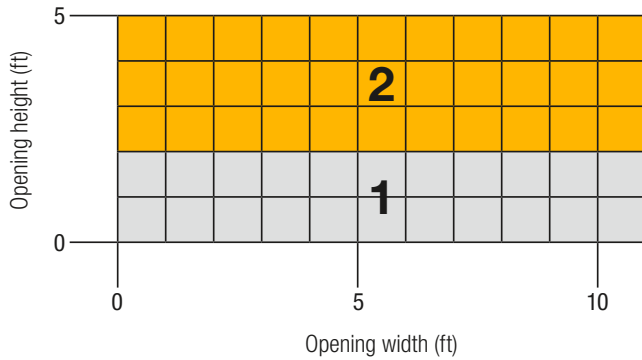

### COMPONENT DIMENSIONS

Reference the zone number to view component dimensions for tube motorized doors.

Dimensions (in)	1	7.75	8	0	0
	2	9.75	10	0	0
	Zone	A	B	C	D

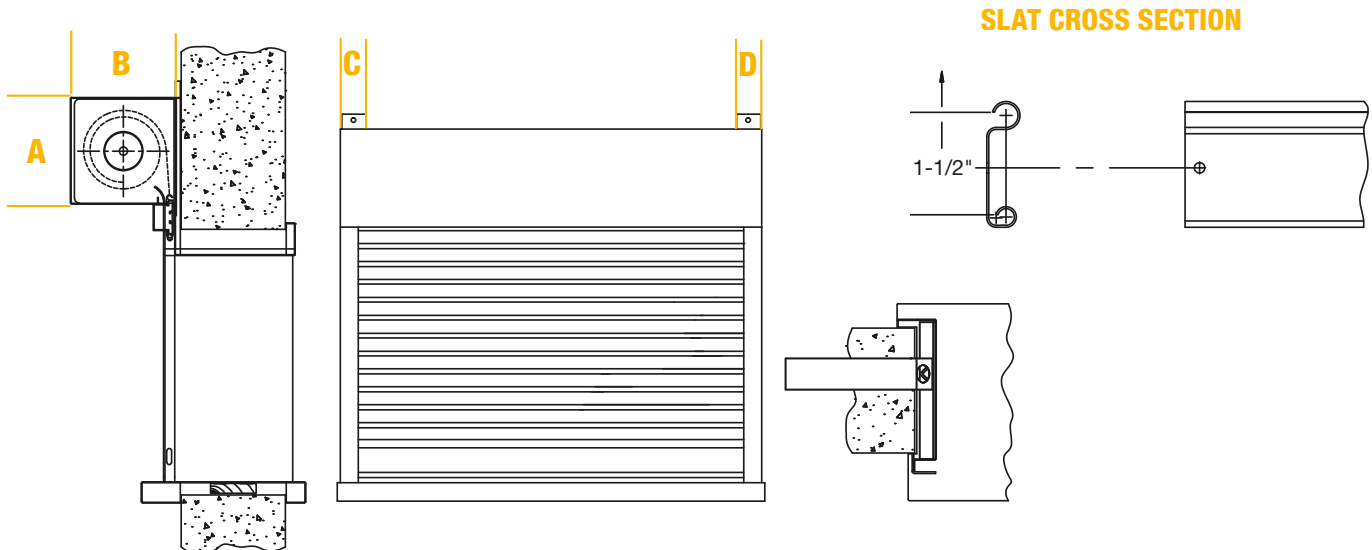

The dimensions featured on this sheet are provided as a rough guide for planning purposes. Exact dimensions cannot be provided until field conditions and all options are confirmed.

# ROLLING COUNTER DOOR

## GUIDE CONSTRUCTION OPTIONS

### FACE OF WALL UNIT



### FACE MOUNTED (BUILT IN)

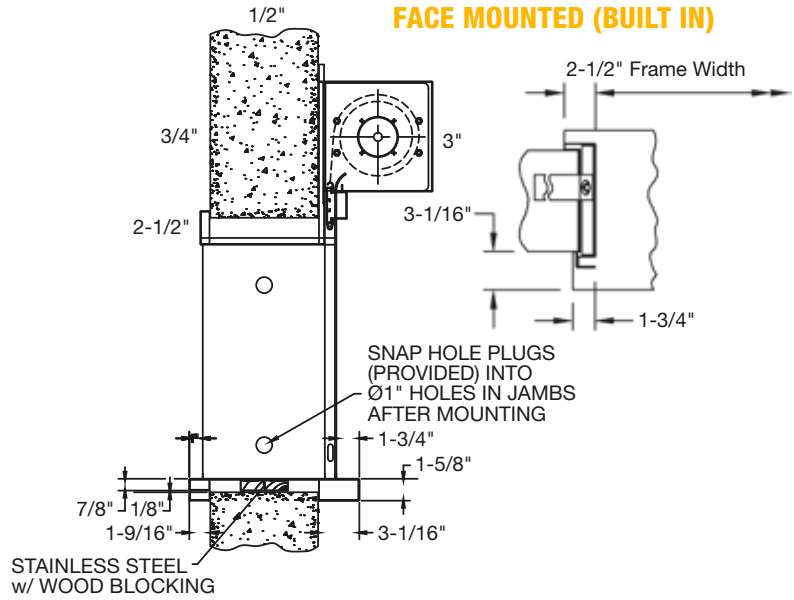

### BETWEEN JAMBS UNIT (SLIP IN)

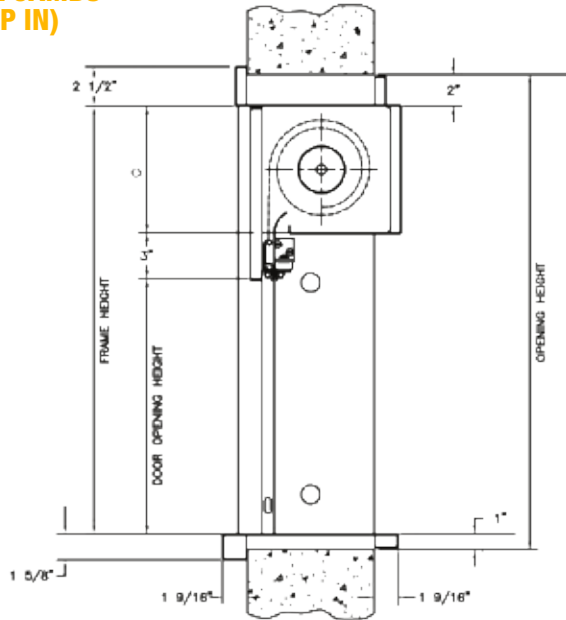

### CLEARANCES

H (CLEAR OPENING HEIGHT)	C
Up to 2'6" inclusive	8"
Over 2'6" to 4'10"	10"

The dimensions featured on this sheet are provided as a rough guide for planning purposes. Exact dimensions cannot be provided until field conditions and all options are confirmed.

### CUSTOM-DESIGNED SOLUTIONS

Contact our experienced Architectural Design Support Team for help in customizing our products to fit your specific application at [www.architectdoorhelp.com](http://www.architectdoorhelp.com).



For more information on these and other Clopay products, visit [clopaycommercial.com](http://clopaycommercial.com). Architects and specifiers, visit [architectdoorhelp.com](http://architectdoorhelp.com).

